

# TN-LC

## A Type B(U)F Transport Package for Commercial and Research Reactor Used Fuel

### New Generation Transport Package for U.S. Domestic and International Shipments

The innovative TN-LC is an NRC-licensed transport package designed to safely handle used fuel from research reactors, full-length commercial irradiated fuel assemblies, irradiated pins to support post-irradiation examinations and other irradiated contents.

### Versatile Package Designed to Hold Different Contents

The TN-LC has been designed to transport various types of fuel pins and assemblies from commercial and research reactors including commercial fuel assemblies (BWR, PWR), rods and pins (EPR, MOX, PWR, BWR), NRU/NRX, TRIGA elements, MTR fuel assemblies and more.

### Lighter and Longer Package With Higher Capacity

The TN-LC can hold long fuel assemblies with a total on the hook weight limited to 25 tons.

#### TN-LC Dimensions:

Outer: 197.5 inches (5,017 mm) long by 44.5 inches (1,130 mm) diameter.

Inner: 182.5 inches (4,636 mm) long by 18.0 inches (457 mm) diameter.

#### TN-LC Capacity:

- 1 PWR/BWR assembly
- 25 PWR/BWR/EPR/MOX pins
- 26 NRU/NRX assemblies
- 54 MTR assemblies
- 180 TRIGA elements

**The TN-LC has a higher capacity than what the market currently offers for this type of application!**

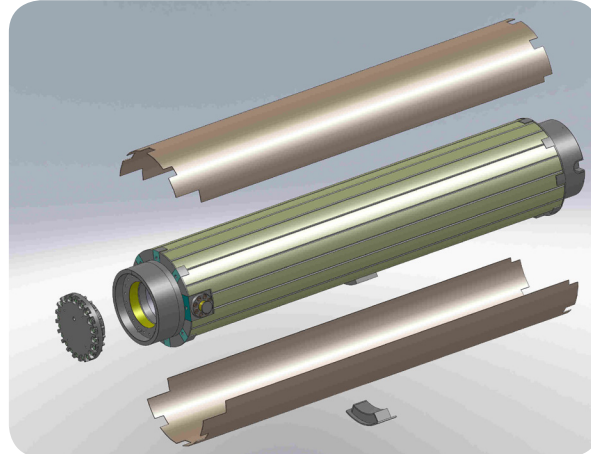

### Transports High Burnup Fuel

The maximum burnup of the TN-LC will depend on its contents; nevertheless it has been designed to accommodate burnups to 660 GWd/TU (90 GWd/TU for the pins).

### Flexible Operation Capabilities

With its 25 ton weight, the TN-LC complies with most commercial or research reactor site weight restrictions.

- Designed to be loaded or unloaded in vertical or horizontal position.
- Can be operated in wet or dry conditions, in fuel pools or hot cells; allowing operation in sites with weight restrictions and shallow pools.

**The TN-LC is a new generation of transport package for the safe transport of used fuel! It is designed to handle a large variety of contents for U.S. domestic and international shipments for commercial and research reactor sites.**

## Designed to perform a variety of shipments for:

- **Research Reactors**
  - **Post-Irradiation Examination**
  - **Commercial Fuel Testing**
- ... and more!

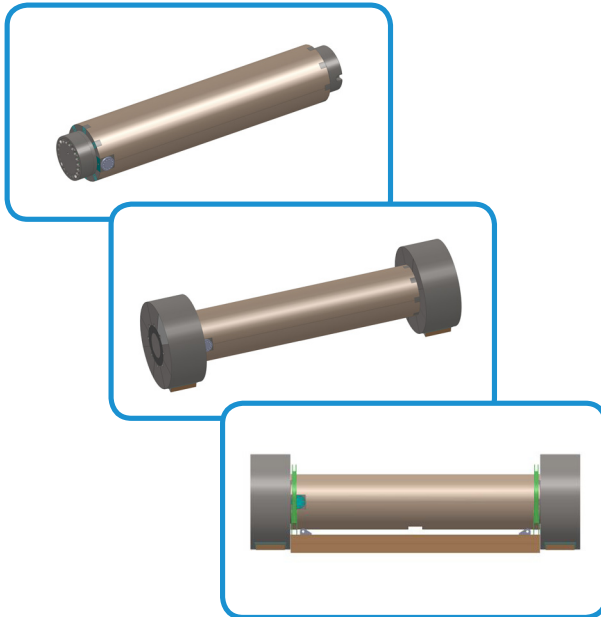

## Features and Benefits

- **NRC-licensed package (CoC 9358):** To perform the U.S. domestic shipments; foreign validations in many countries are underway.
- **Versatile:** Can hold several types of fuel pins and assemblies, including long fuel pins.
- **Cost-effective:** Higher transport capacity per shipment than the market currently offers.
- **Flexible:** Designed to be operated in different loading and unloading configurations in commercial or research environments.

### AREVA TN Americas

#### Jeffery Isakson, VP, Sales & Marketing

7135 Minstrel Way, Suite 300  
Columbia, MD 21045 USA  
Tel: 410 910 6810  
[www.us.aveva.com/AREVATN](http://www.us.aveva.com/AREVATN)

For more information,  
contact your VP, Key Account:  
Tel: 704 805 2305 – Fax: 434 382 5629  
[regional.manager@aveva.com](mailto:regional.manager@aveva.com) – [www.us.aveva.com](http://www.us.aveva.com)

## About AREVA TN

AREVA TN, a division of AREVA Inc., is a leader in the American nuclear market offering innovative total systems solutions for used fuel and radioactive waste management and transportation. More than 50 percent of American nuclear plant operators use AREVA TN's used fuel storage or transport solutions, irradiated waste removal and processing, and pool to pad services.

As part of AREVA, the global leader in nuclear technology, AREVA TN offers the industry an unparalleled level of engineering, technical and logistics expertise.

AREVA TN's track record of providing safe storage and transportation of used fuel is driven by state-of-the-art products and services, innovative engineering solutions, and integrity in meeting customer expectations for low-dose and error-free campaigns. AREVA TN customers include utilities, reactor operators, research reactors and the U.S. government.

AREVA TN's products are marked by the highest standard of safety, uncompromising commitment to quality and operational dependability, and "as promised" service integrity.

The data and information contained herein are provided solely for illustration and informational purposes and create no legal obligations by AREVA TN or any AREVA Group company. None of the information or data is intended by AREVA TN or any AREVA Group company to be a representation or a warranty of any kind, expressed or implied, and AREVA TN or any AREVA Group company assumes no liability for the use of or reliance on any information or data disclosed in this document. © 2014 AREVA Inc. All rights reserved.